

# Vertical Mailboxes – 3500 Series

## Installation Instructions

**PLEASE SEE IMPORTANT INSTRUCTIONS ON BACK**

With their durable powder coat finish and all aluminum construction, 3500 series vertical mailboxes will provide years of maintenance free service.

These units are U.S.P.S. approved to the required security upgrades of USPS-STD-4B+ effective March 2005.

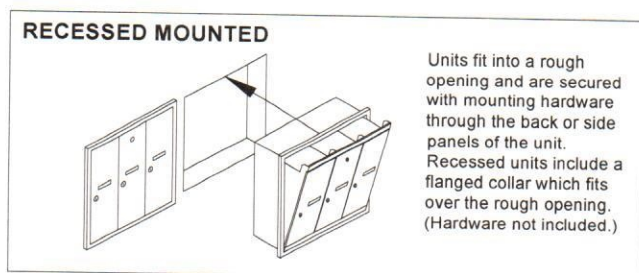
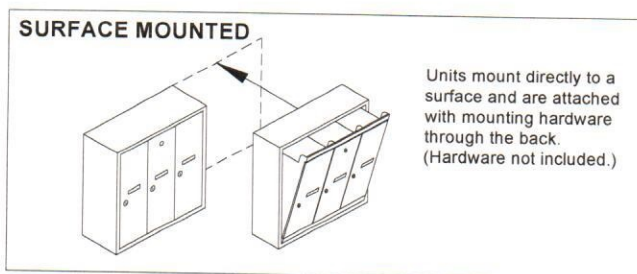

### Notes

1. No more than two tiers of mailboxes may be installed.
2. Wall opening and lumber frame must be square.
3. Mailboxes should be shielded from direct weather conditions.
4. Store keys in a safe place until ready for use.
5. Hardware is not included to fasten units into rough opening.

### Installation Instructions

1. If recessed unit, create rough opening in wall per dimensions in Rough Opening Table. Units must be securely supported by a frame constructed of 2"x4" lumber.

2. Remove unit from carton and place in an upright position on a table or other flat surface.

3. Remove the compartment assembly from the frame by tilting the compartment assembly forward until it extends approximately two inches from the frame. Then lift the compartment assembly upward so that its base clears the hinge pins located at the bottom of the unit. Swing the lower end of the compartment assembly outward and remove it from the frame.

4. Mount the frame in the desired location. **Caution: Do not deform, force, or twist the frame to fit an incorrect rough opening or irregular surface.** If the frame becomes deformed, it will not retain proper alignment with the compartment assembly. Units serviced by the United States Postal Service must be installed with the master lock opening a minimum of 30" and a maximum of 58" above the finished floor.

5. Replace the compartment assembly into the frame, reversing the procedure in step 3 above.

### Surface unit dimensions

### Recessed unit rough opening dimensions

SURFACE	Width	Height		Depth
3503	18-3/4"	19"		7-1/2"
3504	24-1/4"	19"		7-1/2"
3505	29-3/4"	19"		7-1/2"
3506	35-1/4"	19"		7-1/2"
3507	40-3/4"	19"		7-1/2"
RECESSED		1-High	2-High	
3503	17-1/4"	17-3/4"	36-3/4"	7-1/2"
3504	22-3/4"	17-3/4"	36-3/4"	7-1/2"
3505	28-1/4"	17-3/4"	36-3/4"	7-1/2"
3506	33-3/4"	17-3/4"	36-3/4"	7-1/2"
3507	39-1/4"	17-3/4"	36-3/4"	7-1/2"

### Security Caution

The tenant door at or near the center of the compartment array, in addition to providing access to a tenant's mail, also provides access to the USPS Arrow Lock that provides access to all compartments. **For the sake of security of the entire compartment array, it is important that this tenant door be securely locked at all times, even if there is no tenant receiving mail via this door.**

**This Product Distributed By:**

**U.S. Mail Supply, Inc.**

3065 North 124th Street

Brookfield, WI 53005-3857

Ph: 800-571-0147 / Fax: 800-589-1068

www.usmailsupply.com



# Arrow Lock Guard – 3500 Series

## Installation Instructions

### **IMPORTANT!**

After installing the mailboxes, contact your local postmaster – the USPS will provide and install its own master lock on your mailbox unit. Hardware for installing the master lock is included in the plastic bag. Please provide the hardware and these instructions to the USPS representative when they arrive to install the lock.

#### INSTRUCTIONS FOR THE USPS REPRESENTATIVE:

- 1.) Unlock and open the door marked 'U.S. MAIL', and pull the top frame forward, exposing all of the mailboxes.
- 2.) Remove the Key from the Arrow Lock so the lock's bolt is extended.
- 3.) Rest the Arrow Lock on the pre-installed Lock Bracket BOTTOM TAB with the bolt facing up and the keyway facing outward (see sketch at right and Photo #3).
- 4.) Insert the key through the large hole in the Lock Bracket and into the Arrow Lock, and then turn the key so the bolt retracts. Now push the lock into place under the Top Tab of the Lock Bracket (see Photo #4).
- 5.) Insert the two long screws through the Lock Bracket holes and through the holes in the Arrow Lock (see sketch). Do not attach the nuts yet.
- 6.) Place the Lock Guard (Photo #6) over the Arrow Lock so the long screws are through its holes, and the Lock Guard rests on TOP of the frame (as shown in sketch).
- 7.) Attach the Lock Nuts to the long screws and tighten using a Phillips screwdriver and an open-end or socket wrench.
- 8.) Screw the short Self-tapping Screws through the Lock Guard and the holes in the frame.
- 9.) Push the frame closed.
- 10.) Turn and remove the Arrow Lock Key, locking the unit. Close and lock the 'U.S. MAIL' door.

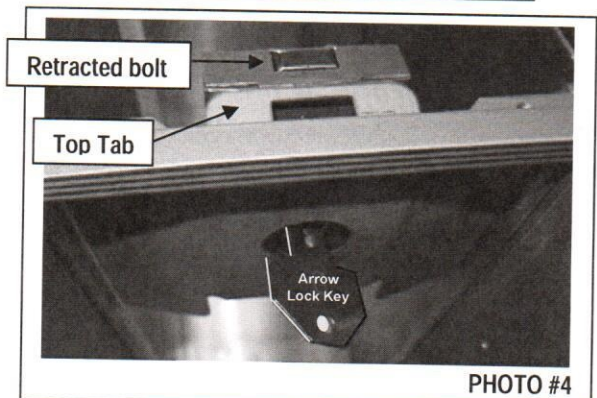
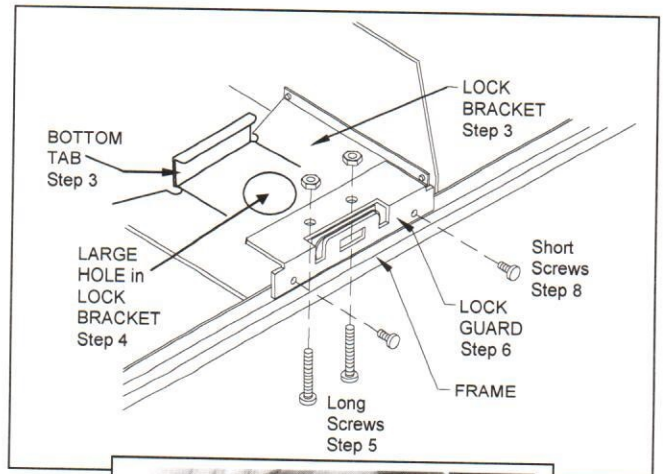

**This Product Distributed By:**

**U.S. Mail Supply, Inc.**

3065 North 124th Street  
Brookfield, WI 53005-3857

Ph: 800-571-0147 / Fax: 800-589-1068

[www.usmailsupply.com](http://www.usmailsupply.com)